



Digital Projection Introduces FUSION Processors -- State-of-the-art Low-Latency Warp and Blend Solutions for Flat and Curved Surfaces

Digital Projection International (DPI) is pleased to present the Fusion suite of warp, blend and network control solutions. The FUSION MD, FUSION 3D and FusionNet control application provide the most advanced single and multi-channel warp and blend processing available - perfectly suited for critical real-time applications needing minimal latency.

The FUSION MD and FUSION 3D processors can be employed with every precision display in DPI's lineup. FusionNet provides network control of the MD and 3D processors, as well as DPI's iVision, dVision, TITAN and LIGHTNING projector lines. No matter what level of projector performance the warp and/or blend application requires, DPI's FUSION suite provides comprehensive capability and integrated system solution.

High quality warp and blend typically incurs a significant penalty of video signal latency. Since delaying audio to match video is easily accomplished, video latency does not present a problem for many applications. However, for real-time applications, such as IMAG and live televised events, where live presenters and the projected images may be visible at the same time, or for simulation, where on-screen imagery must immediately respond to trainee input, video latency must be as close to zero as possible.

DPI's FUSION MD and FUSION 3D processors were created to specifically provide the most advanced multi channel warp and blend for these critical real-time applications. The advanced architecture of the FUSION processors results in video latency that typically equates to a just a few lines of single-video frame, amounting to near-zero latency. Considering the precise warp and blend being performed, the electronic transparency of the FUSION processors is beyond compare.

From a system design perspective, one FUSION MD or FUSION 3D processor is dedicated to each projector in the application. The input source for each projector simply loops through the related FUSION processor, then into the projector. FusionNet, DPI's new network control application is connected to the FUSION Processors and projectors via LAN, providing complete access to all adjustments by way of an easy to use, highly capable desktop application. Warp, blend and projector alignments, for as many channels as the application requires, are intuitive and precise.

FUSION MD, FUSION 3D and FusionNet - comprehensively capable, low latency warp and blend solutions for the most demanding complex screen applications - proving once again that Digital Projection delivers powerful displays for the most demanding venues in the world.

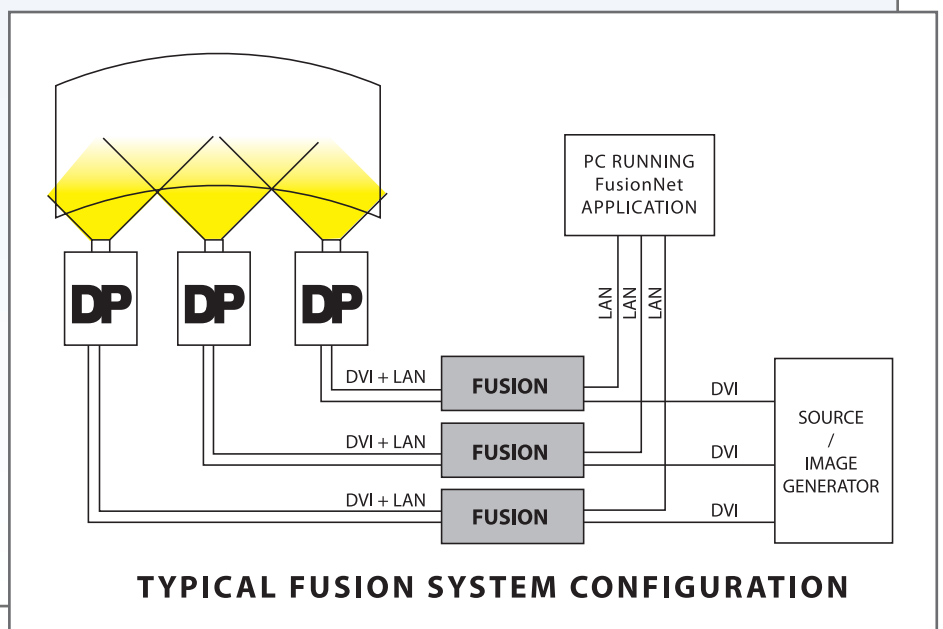

FUSION Suite

Advanced Warp, Blend and System Control

DIGITAL  **PROJECTION**
Precision Displays for Every Venue



Digital Projection's FUSION MD and FUSION 3D Processors are powerful warp and blend engines that deliver a comprehensive set of benefits for simulation, scientific visualization, medical imaging and entertainment applications. Engineered around a technology platform that results in no incremental latency, Fusion Processors provide ultra high quality warp and blend with Black Level Matching and Pixel Level Matching for color correction. These patented capabilities assure every pixel is color and brightness matched for absolute image integrity.

Key features of the Fusion Processors include:

Fully WQXGA (2560 x 1600) compatible

The FUSION 3D Processor features 6.25 Mps image processing for full 2560x1600 image processing without any bandwidth limitations. Featuring Dual Link DVI in/out, the system easily warps, blends and color manages any resolution up to WQXGA, making it forward compatible with next generation displays. The Fusion MD Processor shares the same capabilities, but with a 1920 x 1200 maximum image resolution. The high bandwidth of both systems enables high frame rates for reduced smear and image artifacts.

Black Level Matching

For truly seamless blending and matching between multiple displays, FUSION Processors feature patented Black Level Matching functionality. Each display channel is equipped with a Fusion Processor, enabling the black level of individual displays to be adjusted on per-pixel level if necessary. The result is a completely uniform multi-channel display.

Pixel Level Matching™ – 3-channel-pixel level gain and lift correction

In addition to Black Level Matching, FUSION Warp and Blend Processors feature individual RGB gain and lift per pixel. This ensures completely uniform images in both color and brightness levels. This advanced capability integrates seamlessly with the display, and can be monitored and corrected directly from the FusionNet™ control and setup application.

4x4 Lanczos or bicubic interpolation adaptive filtering

The high-speed dual-core processor in the FUSION enables very sophisticated filtering and scaling filters. Several types of filtering can be selected and applied. Applying the acclaimed 4x4 Lanczos filtering method in a random pattern to blend and correction zones retains a very high degree of detail and sharpness also when the image is electronically corrected.

Unlimited scalability

There are no scalability limitations when using the FUSION processing system. Any number of channels can be combined to a single image, without constraints.

Zero latency for Blend. Minimal latency for Warp

Blending several Image Generators and projectors together for a single, multiple channel image is achieved with absolute zero incremental video latency. Applications that require geometry correction benefit from the least possible latency, typically less than one frame, even when warping to the most unusual screen geometries. Total latency is only dependent on the amount of rotation correction employed.

3D stereoscopic displays

The FUSION 3D supports up to 1920x1200 at a full 120Hz refresh rate active 3D stereo, with full warp and blend capabilities. This makes it easy to assemble a fully immersive system of corrected 3D displays.

Rack mount hardware

Each FUSION processor is half-width, 1U standard size, so two channels can be combined in a single standard 19" 1RU rack mounting plate. Each FUSION processor also features its own internal power supply, so power management is easy, as there is no wall-wart or external power supply module.

Fusion processors are not HDCP compliant.

Product	Part #
FUSION MD Processor.....	110-584
FUSION 3D Processor.....	110-585
FusionNet Software.....	included